

# PORTA-PAK *Specials*



## BRASS FITTINGS

**P/N 19510**

- Manufactured from virgin high density brass alloy
- Pressure – 1,200 psi operating  
Proof pressure up to 15,000 psi for 1/8" and 1/4" pipe, 5,000 psi on larger sizes
- Temperature: -65°F to +250°F at 1,000 psi
- Use with brass, copper or iron pipe

QUANTITY	BRASS FITTING SIZE	PART #
8	1/8 PLUG HEX HEAD - PIPE	54422
4	1/4 PLUG HEX HEAD - PIPE	54423
4	1/4 x 1/8 REDUCING COUPLING - PIPE	54233
3	3/8 x 1/8 REDUCING COUPLING - PIPE	54234
8	1/8 COUPLING - PIPE	54273
4	1/4 COUPLING - PIPE	54274

# STAINLESS AND BRASS FASTENERS



- **316 and 18-8 Stainless Steel Alloy Fasteners for Superior Resistance to Rust, Corrosion, Acids and Chemicals**
- **Hex Head and Socket Cap Screws, Set Screws, Machine Screws, Metal Screws and Threaded Rod**
- **Quality Brass Machine Screws, Nuts and Washers**

**CHROMATE STAINLESS AND BRASS FASTENERS ASSURE FAST, EASY INSTALLATION FOR THOUSANDS OF APPLICATIONS.** Manufactured from the finest materials, they prove to be stronger and more durable. Always use Chromate Stainless and Brass Fasteners when quality and reliability are of utmost importance.



**CHROMATE INDUSTRIAL CORP.**

*EXCEPTIONAL PRODUCTS, SERVICE AND INNOVATIVE SOLUTIONS*



# 316 STAINLESS STEEL CAP SCREWS

## HEX HEAD

Superior corrosion resistance to chemicals and sea water. High molybdenum content, high temperature strength and non-magnetic.

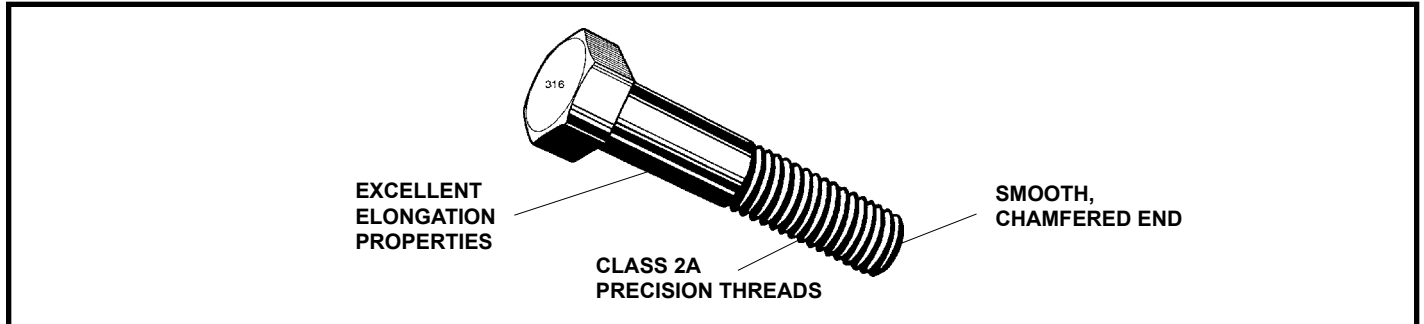

LENGTH	1/4 DIA.		5/16 DIA.		3/8 DIA.		1/2 DIA.		5/8 DIA.	3/4 DIA.
	USS 20	SAE 28	USS 18	SAE 24	USS 16	SAE 24	USS 13	SAE 20	USS 11	USS 10
1/2	T 13100		R 13143		R 13605		-		-	
3/4	T 13106		R 13149		R 13186		-		-	
1	T 13109		R 13152		R 13189		L 13246	E 13609	I 13613	
1-1/4	R 13112	N 13601	R 13155	K 13603	R 13192		I 13608	E 13610	E 13281	
1-1/2	R 13115		R 13158		N 13195		L 13252		E 13282	
1-3/4	R 13118	N 13602	-	13604	N 13198	13607	L 13253	B 13611	E 13283	
2	R 13121		R 13164		N 13201		I 13258	C 13612	E 13286	C 13614
2-1/4	R 13600		-		L 13606		I 13259		E 13287	
2-1/2	R 13124		N 13167		L 13204		I 13261		E 13288	C 13615
2-3/4	-		-		-		-		E 13289	
3	R 13127		N 13170		L 13207		E 13264		E 13290	C 13616
3-1/2	-		N 13171		-		E 13267		E 13292	B 13617
4	-		N 13172		L 13209		-		E 13294	
5	-		-		-		-		E 13296	

# 316 STAINLESS STEEL NUTS AND WASHERS

## USE WITH 316 STAINLESS STEEL CAP SCREWS

HEX NUTS							
SIZE	TPI		WAF	HGT	PART		
	USS	SAE			USS	SAE	
1/4"	20	28	7/16	7/32	T 13300	T 13301	
5/16"	18	24	1/2	17/64	T 13302	T 13303	
3/8"	16	24	9/16	21/64	T 13304	R 13305	
1/2"	13	20	3/4	7/16	R 13308	N 13309	
5/8"	11	18	15/16	35/64	N 13312		-
3/4"	10	16	1-1/8	41/64	N 13314		-

FLATWASHERS			
SIZE	I.D.	O.D.	PART
1/4"	9/32	5/8	T 13510
5/16"	11/32	11/16	T 13512
3/8"	13/32	13/16	T 13514
1/2"	17/32	1-1/16	R 13518
5/8"	21/32	1-5/16	R 13522
3/4"	13/16	1-7/8	I 13524

LOCKWASHERS		
SIZE		PART
1/4"	U	13410
5/16"	T	13412
3/8"	T	13414
1/2"	R	13418
5/8"	N	13422
3/4"	N	13424

# 18-8 STAINLESS STEEL CAP SCREWS

## HEX HEAD

Resists rust, corrosion, acids and chemicals.

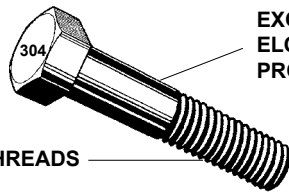

EXCELLENT  
ELONGATION  
PROPERTIES



CLASS 2A  
PRECISION THREADS

SMOOTH,  
CHAMFERED END

LENGTH	1/4 DIA.		5/16 DIA.		3/8 DIA.		7/16 DIA.	1/2 DIA.	5/8 DIA.	3/4 DIA.
	USS 20	SAE 28	USS 18	SAE 24	USS 16	SAE 24	USS 14	USS 13	USS 11	USS 10
1/2	T 14100	-	T 14143		R 14180		-	-	-	-
5/8	T 14103	-	T 14146		R 14183		-	-	-	-
3/4	T 14106	T 14105	T 14149	R 14148	R 14186	R 14185	-	N 14243	-	-
1	T 14109	T 14108	T 14152	R 14151	R 14189	R 14188	N 14220	N 14246	-	-
1-1/4	T 14112	-	R 14155		R 14192		N 14223	N 14249	I 14280	I 14381
1-1/2	T 14115	T 14114	R 14158	R 14157	N 14195	N 14194	N 14226	L 14252	I 14282	I 14382
1-3/4	T 14118	-	R 14161		N 14198		N 14228	L 14255	I 14284	I 14383
2	R 14121	R 14120	N 14164	N 14163	N 14201	N 14200	N 14230	L 14258	I 14286	I 14384
2-1/4	-	-	-	-	-	-	-	L 14259	-	-
2-1/2	R 14124	-	N 14167		N 14204		L 14233	L 14261	I 14288	E 14386
2-3/4	-	-	-	-	-	-	-	-	I 14289	-
3	N 14127	-	L 14170		L 14207		L 14236	L 14264	I 14290	E 14388
3-1/2	N 14130	-	L 14173		L 14210		-	I 14267	E 14292	E 14390
4	L 14133	-	L 14176		L 14213		-	I 14270	E 14294	E 14392
5	L 14136	-	I 14177		I 14216		-	E 14273	E 14296	E 14394
5-1/2	-	-	-	-	-	-	-	E 14274	C 14297	B 14395
6	-	-	I 14179		-		-	E 14275	E 14298	E 14396

# 18-8 STAINLESS STEEL NUTS AND WASHERS

## FOR 18-8 STAINLESS STEEL CAP SCREWS

### HEX NUTS

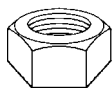

SIZE	TPI		WAF	HGT	PART	
	USS	SAE			USS	SAE
1/4"	20	28	7/16	7/32	T 14300	T 14301
5/16"	18	24	1/2	17/64	T 14302	T 14303
3/8"	16	24	9/16	21/64	T 14304	T 14305
7/16"	14	20	11/16	3/8	R 14306	T 14307
1/2"	13	20	3/4	7/16	N 14308	R 14309
9/16"	12	18	7/8	31/64	N 14310	-
5/8"	11	18	15/16	35/64	L 14312	N 14313
3/4"	10	16	1-1/8	41/64	L 14314	N 14315
7/8"	9	14	1-5/16	3/4	I 14316	-
1"	8	14	1-1/2	55/64	E 14318	C 14319
1-1/8"	7	14	-	-	C 14320	-

### NYLON LOCK NUTS



- SPECIAL PRIME STAINLESS STEEL
- ONE-PIECE NYLON INSERT FOR POSITIVE 360° LOCKING
- REUSABLE
- CHROMATE PROTECTIVE PLATING



SIZE	TPI		WAF	PART	
	USS	SAE		USS	SAE
1/4"	20	28	7/16	T 14350	T 24350
5/16"	18	24	1/2	T 14351	T 24351
3/8"	16	24	9/16	T 14352	T 24352
7/16"	14	20	5/8	N 14353	N 24353
1/2"	13	20	3/4	N 14354	N 24354
9/16"	12	18	7/8	B 14358	B 24358
5/8"	11	18	15/16	I 14355	I 24355
3/4"	10	16	1-1/8	E 14356	E 24356
7/8"	9	14	1-5/16	E 14359	E 24359
1"	8	14	1-1/2	B 14357	B 24357

### HEX JAM NUTS

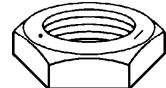

- IDEAL FOR CHEMICAL MACHINE AND OTHER CORROSIVE ENVIRONMENTS
- COARSE AND FINE THREADS



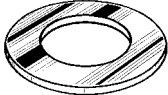

SIZE	TPI		WAF	PART	
	USS	SAE		USS	SAE
1/4"	20	28	7/16	T 15850	T 15870
5/16"	18	24	1/2	T 15851	T 15871
3/8"	16	24	9/16	T 15852	T 15872
7/16"	14	20	11/16	T 15853	R 15873
1/2"	13	20	3/4	R 15854	R 15874
5/8"	11	18	15/16	R 15856	N 15875
3/4"	10	16	1-1/8	N 15857	N 15876
7/8"	9	14	1-5/16	I 15858	E 15877
1"	8	14	1-1/2	E 15859	B 15878

# 18-8 STAINLESS STEEL NUTS AND WASHERS (Cont'd.)

SAE MS FLATWASHERS				
				
SIZE	I.D.	O.D.	PART	
1/4	9/32	5/8	U	14460
5/16	11/32	11/16	T	14462
3/8	13/32	13/16	T	14464
7/16	15/32	59/64	T	14466
1/2	17/32	1-1/16	T	14468
9/16	19/32	1-3/16	R	14470
5/8	21/32	1-5/16	R	14472
3/4	13/16	1-1/2	R	14474
7/8	15/16	1-3/4	L	14476
1	1-1/16	2	L	14478

USS COMM. FLATWASHERS				
 				
SIZE	I.D.	O.D.	THICK	PART
1/4	9/32	5/8	.045	U 14510
5/16	11/32	3/4	.045	T 14512
3/8	13/32	1	.045	T 14514
7/16	1/2	1-1/8	.062	T 14516
1/2	17/32	1-1/4	.062	T 14518
9/16	5/8	1-3/8	.078	R 14520
5/8	11/16	1-1/2	.078	R 14522
3/4	13/16	1-7/8	.109	N 14524
7/8	15/16	2	.109	L 14526
1	1-1/16	2	.125	L 14528

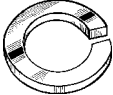
USS MS FLATWASHERS				
• MS 15795 				
SIZE	I.D.	O.D.	THICK	PART
1/4	5/16	3/4	.051-.080	T 15602
5/16	3/8	7/8	.064-.104	T 15606
3/8	7/16	1	.064-.104	T 15610
7/16	1/2	1-1/4	.064-.104	T 15614
1/2	9/16	1-3/8	.086-.132	R 15618
5/8	11/16	1-3/4	.108-.160	N 15622
3/4	13/16	2	.122-.177	N 15626
7/8	15/16	2-1/4	.136-.192	I 15630
1	1-1/16	2-1/2	.136-.192	I 15634

LOCKWASHERS			
• HARDNESS 35Rc MIN.  			
SIZE	PART	SIZE	PART
1/4	U 14410	9/16	R 14420
5/16	T 14412	5/8	R 14422
3/8	T 14414	3/4	N 14424
7/16	T 14416	7/8	N 14426
1/2	T 14418	1	N 14428

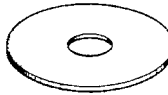
FENDER WASHERS							
							
SIZE	O.D.	I.D.	PART	SIZE	O.D.	I.D.	PART
3/16	1	7/32	T 14430	5/16	1-1/2	11/32	T 14435
1/4	1	9/32	T 14431	3/8	1-1/4	13/32	T 14436
1/4	1-1/4	9/32	T 14432	3/8	1-1/2	13/32	T 14437
1/4	1-1/2	9/32	T 14433	1/2	2	17/32	N 14438
5/16	1-1/4	11/32	T 14434	-	-	-	-

# 18-8 STAINLESS STEEL CAP SCREWS

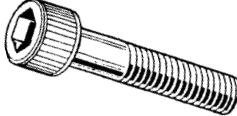
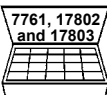
HEX SOCKET HEAD									
<ul style="list-style-type: none"> <li>• THREAD - CLASS 3A FIT. ANSI B1.1</li> <li>• DIMENSIONS TO ANSI B18.3</li> </ul>  									
LENGTH	4-40	6-32	8-32	10-24	10-32	1/4-20	5/16-18	3/8-16	1/2-13
1/4	T 15102	T 15117	-	-	-	-	-	-	-
3/8	T 15105	T 15120	T 15138	T 15163	T 15188	T 15216	-	-	-
1/2	T 15108	T 15123	T 15141	T 15166	T 15191	T 15219	R 15247	R 15272	-
5/8	T 15111	T 15126	T 15144	T 15169	T 15194	R 15222	R 15250	N 15275	-
3/4	T 15114	T 15129	T 15147	T 15172	T 15197	R 15225	R 15253	N 15278	-
7/8	-	-	-	T 15175	T 15200	R 15228	N 15254	N 15279	-
1	T 15115	T 15130	T 15153	T 15176	T 15203	R 15231	R 15256	N 15281	I 15300
1-1/4	-	T 15131	R 15154	R 15178	R 15206	R 15234	R 15259	N 15284	I 15303
1-1/2	-	R 15132	R 15155	R 15181	R 15209	R 15237	N 15262	N 15287	I 15306
1-3/4	-	-	-	-	-	R 15240	N 15265	N 15290	I 15309
2	-	-	-	R 15183	R 15211	N 15243	N 15268	N 15293	I 15312
2-1/2	-	-	-	-	-	N 15244	N 15269	I 15294	I 15315
3	-	-	-	-	-	N 15245	I 15270	I 15295	E 15317
3-1/2	-	-	-	-	-	I 15246	E 15271	I 15296	E 15318
4	-	-	-	-	-	I 15248	E 15273	E 15297	B 15319

# 18-8 S/S HEX SOCKET CAP SCREWS

## FLAT HEAD

DEEP SOCKET PROVIDES STRONGER HEX KEY ENGAGEMENT

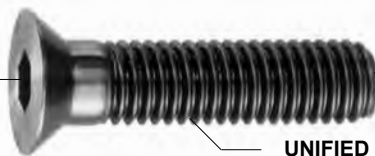

SMOOTH, CHAMFERED END ASSURES EASY THREADING



• DIMENSIONS TO ANSI B18.3

UNIFIED 3A THREAD FIT

LENGTH	NO. 4		NO. 6		NO. 8		NO. 10		1/4 DIA.	5/16 DIA.	3/8 DIA.	1/2 DIA.
	USS 40	USS 32	USS 32	USS 32	USS 24	SAE 32	USS 20	USS 18	USS 16	USS 13		
1/4	T 47800	T 47805	T 47810	-	-	-	-	-	-	-	-	-
3/8	T 47801	T 47806	T 47811	T 47815	47819	-	-	-	-	-	-	-
1/2	T 47802	T 47807	T 47812	T 47816	47820	-	T 47823	R 47829	-	-	-	-
3/4	T 47803	T 47808	T 47813	T 47817	47821	-	T 47824	R 47830	N 47835	I 47840	-	-
1	T 47804	T 47809	T 47814	T 47818	47822	-	T 47825	R 47831	N 47836	I 47841	-	-
1-1/4	-	-	-	-	-	-	R 47826	R 47832	N 47837	I 47842	-	-
1-1/2	-	-	-	-	-	-	R 47827	N 47833	N 47838	I 47843	-	-
2	-	-	-	-	-	-	R 47828	N 47834	I 47839	E 47844	-	-

## BUTTON HEAD

DEEP SOCKET PROVIDES STRONGER HEX KEY ENGAGEMENT

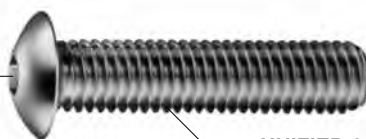

SMOOTH, CHAMFERED END ASSURES EASY THREADING



• DIMENSIONS TO ASME/ANSI B18.3

UNIFIED 3A THREAD FIT

LENGTH	NO. 4		NO. 6		NO. 8		NO. 10		1/4 DIA.	5/16 DIA.	3/8 DIA.	1/2 DIA.
	USS 40	USS 32	USS 32	USS 32	USS 24	SAE 32	USS 20	USS 18	USS 16	USS 13		
1/4	T 47850	T 47855	T 47860	-	-	-	-	-	-	-	-	-
3/8	T 47851	T 47856	T 47861	T 47865	47869	-	-	-	-	-	-	-
1/2	T 47852	T 47857	T 47862	T 47866	47870	-	T 47873	R 47879	-	-	-	-
3/4	T 47853	T 47858	T 47863	T 47867	47871	-	T 47874	R 47880	N 47885	I 47890	-	-
1	T 47854	T 47859	T 47864	T 47868	47872	-	T 47875	R 47881	N 47886	I 47891	-	-
1-1/4	-	-	-	-	-	-	R 47876	R 47882	N 47887	I 47892	-	-
1-1/2	-	-	-	-	-	-	R 47877	N 47883	N 47888	I 47893	-	-
2	-	-	-	-	-	-	R 47878	N 47884	I 47889	E 47894	-	-

# 18-8 S/S CARRIAGE BOLTS

- MIN. TENSILE 100,000 - 125,000 PSI
- HEAD AND BODY TO ANSI B18.5
- THREAD: CLASS 2A FIT ANSI B1.1
- FULLY THREADED TO 4" LENGTH

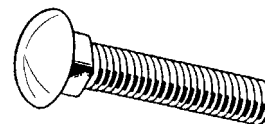

LENGTH	1/4-20	5/16-18	3/8-16	LENGTH	1/4-20	5/16-18	3/8-16
3/4	T 8669	-	R 8689	2-1/2	R 8675	R 8685	R 8696
1	T 8670	T 8680	T 8690	3	R 8677	N 8686	I 8697
1-1/4	T 8671	-	T 8691	3-1/2	-	-	I 8698
1-1/2	T 8672	T 8682	N 8692	4	R 8679	N 8688	-
2	T 8674	R 8684	N 8693				

# 18-8 STAINLESS STEEL SOCKET SET SCREWS

- MEETS ANSI B18.3
- MIN. TENSILE 100,000 - 125,000 PSI
- YIELD - 55,000 - 75,000 PSI
- HARDNESS - 100 ROCKWELL B
- THREAD DIAMETER TO CLASS 3A FIT ANSI B1.1



LENGTH	4-40	6-32	8-32	10-24	10-32	1/4-20	5/16-18	3/8-16	1/2-13
<b>1/8</b>	T 15326	T 15342	T 15361	-	-	-	-	-	-
<b>3/16</b>	T 15329	T 15345	T 15364	T 15380	T 15400	T 15420	-	-	-
<b>1/4</b>	T 15332	T 15348	T 15367	T 15383	T 15403	T 15423	T 15440	-	-
<b>3/8</b>	T 15335	T 15351	T 15370	T 15386	T 15406	T 15426	T 15443	R 15457	-
<b>1/2</b>	T 15338	T 15354	T 15373	T 15389	T 15409	T 15429	R 15446	R 15460	N 15474
<b>5/8</b>	-	-	-	T 15392	T 15412	R 15432	-	R 15463	N 15477
<b>3/4</b>	-	T 15357	-	R 15395	R 15415	R 15435	R 15453	R 15466	N 15480
<b>1</b>	-	-	-	-	-	-	-	N 15469	N 15483

# 18-8 STAINLESS STEEL MACHINE SCREWS

## SLOTTED PAN, FLAT AND ROUND HEADS

### PAN HEAD

- PRECISION BURR-FREE THREADS FOR EXACT FIT
- MEETS ANSI B18.6.3
- MIN. TENSILE 100,000 - 125,000 PSI
- YIELD - 55,000 - 75,000 PSI
- HARDNESS - 100 ROCKWELL B

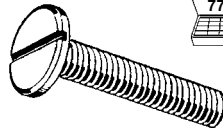

### FLAT HEAD

- PRECISION BURR-FREE THREADS FOR EXACT FIT
- MEETS ANSI B18.6.3
- MIN. TENSILE 100,000 - 125,000 PSI
- YIELD - 55,000 - 75,000 PSI
- HARDNESS - 100 ROCKWELL B

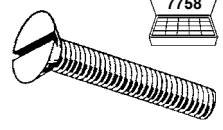

LENGTH	4-40	5-40	6-32	8-32	10-24	10-32	1/4-20	4-40	6-32	8-32	10-24	10-32	1/4-20
<b>1/4</b>	T 14700	T 14711	T 14720	T 14742	T 14800	T 14765	-	T 14900	T 14920	T 14942	T 15000	T 14965	-
<b>3/8</b>	T 14702	T 14713	T 14722	T 14744	T 14802	T 14768	T 14826	T 14902	T 14922	T 14944	T 15002	T 14968	T 15026
<b>1/2</b>	T 14704	T 14715	T 14724	T 14746	T 14804	T 14770	T 14828	T 14904	T 14924	T 14946	T 15004	T 14970	T 15028
<b>5/8</b>	T 14706	T 14716	T 14726	T 14748	-	T 14772	T 14830	T 14906	T 14926	T 14948	T 15006	T 14972	T 15030
<b>3/4</b>	T 14708	T 14717	T 14728	T 14750	T 14808	T 14774	T 14832	T 14908	T 14928	T 14950	T 15008	T 14974	T 15032
<b>1</b>	T 14710	T 14718	T 14730	T 14752	T 14810	T 14776	T 14834	T 14910	T 14930	T 14952	T 15010	T 14976	T 15034
<b>1-1/4</b>	T 14712	-	T 14732	T 14754	T 14812	T 14778	T 14836	T 14912	T 14932	T 14954	T 15012	T 14978	T 15036
<b>1-1/2</b>	T 14714	T 14719	T 14734	T 14756	T 14814	T 14780	T 14838	T 14914	T 14934	T 14956	T 15014	T 14980	T 15038
<b>1-3/4</b>	-	-	-	T 14758	T 14816	T 14782	R 14840	-	T 14936	T 14958	T 15016	T 14984	R 15040
<b>2</b>	-	-	U 14738	T 14760	T 14818	T 14784	R 14842	-	T 14938	T 14960	T 15018	T 14986	R 15042
<b>2-1/2</b>	-	-	-	-	-	-	R 14844	-	-	-	-	-	R 15044
<b>3</b>	-	-	-	-	-	-	R 14846	-	-	-	-	-	R 15046

### ROUND HEAD

- MEETS ANSI B18.6.3
- MIN. TENSILE 100,000 - 125,000 PSI
- YIELD - 55,000 - 75,000 PSI
- HARDNESS - 100 ROCKWELL B

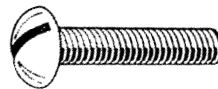

MICRO SIZES 0-80 TO 3-48



LENGTH	0-80	1-72	2-56	3-48	LENGTH	0-80	1-72	2-56	3-48
<b>1/8</b>	T 25235	T 25243	T 25251	25262	<b>5/8</b>	T 25241	T 25249	T 25257	T 25268
<b>3/16</b>	T 25236	T 25244	T 25252	T 25263	<b>3/4</b>	T 25242	T 25250	T 25258	T 25269
<b>1/4</b>	T 25237	T 25245	T 25253	T 25264	<b>7/8</b>	-	-	T 25259	-
<b>5/16</b>	T 25238	T 25246	T 25254	T 25265	<b>1</b>	-	-	T 25260	T 25270
<b>3/8</b>	T 25239	T 25247	T 25255	T 25266	<b>1-1/2</b>	-	-	T 25261	-
<b>1/2</b>	T 25240	T 25248	T 25256	T 25267					



# 18-8 STAINLESS STEEL MACHINE SCREWS (Cont'd.)

## PHILLIPS PAN, FLAT AND OVAL HEADS

### PAN HEAD

- MEETS ANSI B18.6.3
- MIN. TENSILE 100,000 - 125,000 PSI
- YIELD – 55,000 - 75,000 PSI
- HARDNESS – 100 ROCKWELL B

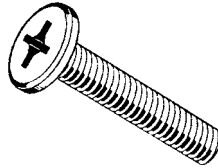

LENGTH	2-56	4-40	6-32	8-32	10-24	10-32	12-24	1/4-20	5/16-18
1/8	T 25000	T 25065	-	-	-	-	-	-	-
3/16	T 25001	T 25066	-	-	-	-	-	-	-
1/4	T 25002	T 25067	T 25073	-	-	-	-	R 25090	-
3/8	T 25003	T 25008	T 25012	T 25019	T 25038	T 25028	T 25084	R 25091	-
1/2	T 25004	T 25009	T 25013	T 25020	T 25039	T 25029	T 25085	T 25048	-
5/8	T 25005	T 25068	T 25074	T 25079	T 25082	T 25083	T 25086	T 25092	-
3/4	T 25006	T 25010	T 25014	T 25021	T 25040	T 25030	T 25087	T 25049	N 25059
1	-	T 25011	T 25015	T 25022	T 25041	R 25031	T 25088	R 25050	N 25060
1-1/4	-	T 25069	T 25016	R 25023	R 25042	R 25032	-	R 25051	-
1-1/2	-	T 25070	R 25017	R 25024	R 25043	R 25033	R 25089	R 25052	N 25061
1-3/4	-	T 25071	T 25075	R 25025	R 25044	R 25034	-	R 25053	-
2	-	T 25072	T 25076	R 25026	R 25045	R 25035	-	R 25054	N 25062
2-1/2	-	-	T 25077	R 25080	R 25046	R 25036	-	R 25055	-
3	-	-	T 25078	R 25081	R 25047	R 25037	-	N 25056	I 25063
3-1/2	-	-	-	-	-	-	-	N 25057	-
4	-	-	-	-	-	-	-	N 25058	E 25064

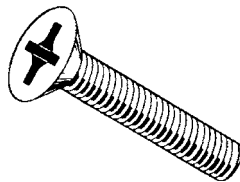

### FLAT HEAD

- MEETS ANSI B18.6.3
- MIN. TENSILE 100,000 - 125,000 PSI
- YIELD – 55,000 - 75,000 PSI
- HARDNESS – 100 ROCKWELL B



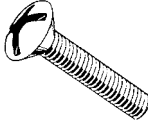

LENGTH	2-56	4-40	6-32	8-32	10-24	10-32	12-24	1/4-20
1/4	T 14890	T 25421	T 25431	T 25444	-	-	-	-
5/16	-	T 25422	T 25432	T 25445	-	-	-	-
3/8	T 14892	T 25423	T 25433	T 25446	T 25457	T 25468	T 25478	T 25485
1/2	T 14894	T 25424	T 25434	T 25447	T 25458	T 25469	T 25479	T 25486
5/8	-	T 25425	T 25435	T 25448	T 25459	T 25470	R 25480	T 25487
3/4	T 14896	T 25426	T 25436	T 25449	T 25460	T 25471	R 25481	T 25488
1	-	T 25427	T 25437	T 25450	T 25461	T 25472	R 25482	R 25489
1-1/4	-	T 25428	T 25438	R 25451	R 25462	R 25473	R 25483	R 25490
1-1/2	-	T 25429	T 25439	R 25452	R 25463	R 25474	R 25484	R 25491
1-3/4	-	-	R 25440	R 25453	-	-	-	R 25492
2	-	-	R 25441	R 25454	R 25464	R 25475	-	R 25493
2-1/2	-	-	R 25442	R 25455	R 25465	R 25476	-	R 25494
3	-	-	R 25443	R 25456	R 25466	R 25477	-	N 25495

# 18-8 STAINLESS STEEL MACHINE SCREWS (Cont'd.)

OVAL HEAD							
<ul style="list-style-type: none"> <li>• MEETS ANSI B18.6.3</li> <li>• MIN. TENSILE 100,000 - 125,000 PSI</li> <li>• YIELD – 55,000 - 75,000 PSI</li> <li>• HARDNESS – 100 ROCKWELL B</li> </ul>							
LENGTH	4-40	6-32	8-32	10-24	10-32	1/4-20	
3/8	T 25100	T 25104	-	-	-	-	-
1/2	T 25101	T 25105	T 25112	T 25126	T 25119	T 25134	
3/4	T 25102	T 25106	T 25113	T 25127	T 25120	T 25135	
1	T 25103	T 25107	T 25114	T 25128	T 25121	R 25136	
1-1/4	-	T 25108	R 25115	R 25129	R 25122	R 25137	
1-1/2	-	R 25109	R 25116	R 25130	R 25123	R 25138	
1-3/4	-	-	-	-	-	R 25139	
2	-	R 25110	R 25117	R 25131	R 25124	R 25140	

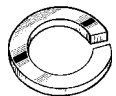

# 18-8 STAINLESS STEEL NUTS AND WASHERS

## FOR 18-8 STAINLESS STEEL MACHINE SCREWS

LOCK WASHERS		
<ul style="list-style-type: none"> <li>• MEETS ANSI B18.21.1</li> <li>• HARDNESS – 35 ROCKWELL C MIN.</li> </ul>		
		
SIZE		PART
#2	U	14398
#3	U	14399
#4	U	14400
#5	U	14401
#6	U	14402
#8	U	14404
#10	U	14406
#12	U	14408
1/4	U	14410

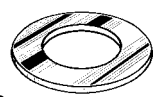
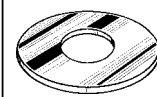
COUNTERSINK FINISHING WASHERS		
		
SIZE		PART
#4	U	14480
#6	U	14481
#8	U	14482
#10	U	14483
#12	U	14484
1/4	U	14485
5/16	T	14486

FLAT WASHERS			
			
SAE MS		USS COMMERCIAL	
SIZE		PART	
#4	U	14450	#2 U 14498
#6	U	14452	#3 U 14497
#8	U	14454	#4 U 14500
#10	U	14456	#5 U 14501
1/4	U	14460	#6 U 14502
-	-	-	#8 U 14504
-	-	-	#10 U 14506
-	-	-	#12 U 14508
-	-	-	1/4 U 14510

NYLON LOCK NUTS		
<ul style="list-style-type: none"> <li>• MIN. TENSILE 100,000 - 125,000 PSI</li> <li>• HARDNESS – 100 ROCKWELL B</li> </ul>		
		
SIZE		PART
2-56	T	14335
3-48	R	14337
4-40	T	14340
5-40	T	14341
6-32	T	14342
8-32	T	14344
10-24	T	14348
10-32	T	14346
12-24	T	14349
1/4-20	T	14350

HEX NUTS		
<ul style="list-style-type: none"> <li>• MIN. TENSILE 100,000 - 125,000 PSI</li> <li>• HARDNESS – 100 ROCKWELL B</li> </ul>		
		
SIZE		PART
0-80	T	14326
1-72	T	14327
2-56	T	14328
3-48	T	14329
4-40	T	14330
5-40	T	14331
6-32	T	14332
8-32	T	14334
10-32 (SAE)	T	14336
10-24	T	14338
12-24	T	14339
1/4-20	T	14300

WING NUTS		
<ul style="list-style-type: none"> <li>• MIN. TENSILE 100,000 - 125,000 PSI</li> <li>• HARDNESS 100 ROCKWELL B</li> </ul>		
		
SIZE		PART
6-32	T	14362
8-32	T	14364
10-24	R	14366
10-32	R	14368
1/4-20	R	14370
5/16	N	14372
3/8	N	14374
1/2	N	14376

# 18-8 STAINLESS STEEL ACORN NUTS

## 18-8 STAINLESS STEEL ACORN NUTS



- HEX SHAPE WRENCHING SURFACE
- CAP SHAPED TOP
- PROVIDES PROTECTION FOR PROJECTING THREADED PARTS
- EXCELLENT IN CORROSIVE ENVIRONMENTS
- COARSE AND FINE THREADS

SIZE	PART	SIZE	PART	SIZE	PART	SIZE	PART
6-32	R 15880	10-32	R 15883	5/16-18	R 15885	1/2-13	I 15887
8-32	R 15881	1/4-20	R 15884	3/8-16	N 15886	5/8-11	E 15888
10-24	R 15882	-	-	-	-	-	-

# 18-8 STAINLESS STEEL METAL SCREWS

## SLOTTED PAN HEAD



## PHILLIPS PAN HEAD

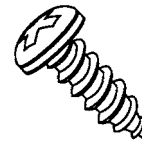

LENGTH	NO. 6	NO. 8	NO. 10	NO. 12	NO. 14	NO. 4	NO. 6	NO. 8	NO. 10	NO. 12	NO. 14
1/4	T 14600	-	-	-	-	T 25300	T 25303	T 25310	T -	T -	T -
3/8	T 14603	-	-	-	-	T 25301	T 25304	T 25311	T 25320	T 25330	T 25340
1/2	T 14606	T 14620	T 14640	T 14660	T 14680	T -	T 25305	T 25312	T 25321	T 25331	T 25341
5/8	T 14609	T 14623	T 14643	T 14663	T 14683	T -	T 25306	T 25313	T 25322	T 25332	T 25342
3/4	T 14612	T 14626	T 14646	T 14666	T 14686	T -	T 25307	T 25314	T 25323	T 25333	T 25343
1	T 14615	T 14629	T 14649	T 14669	T 14689	T -	T -	T 25315	T 25324	T 25334	T 25344
1-1/4	-	T 14632	T 14652	T 14672	T 14692	T -	T -	T 25316	T 25325	T 25335	T 25345
1-1/2	-	-	T 14655	T 14675	T 14695	T -	T -	T -	T -	T 25336	R 25346
1-3/4	-	-	-	-	-	T -	T -	T -	T -	T 25337	R 25347
2	-	-	-	-	-	T -	T -	T 25317	T 25326	T 25337	R 25347
2-1/2	-	-	-	-	-	T -	T -	T 25318	T 25327	-	-

## PHILLIPS OVAL HEAD

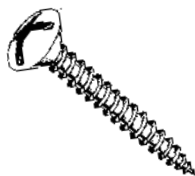

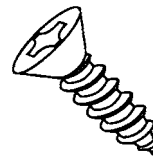

## PHILLIPS FLAT HEAD



LENGTH	NO. 4	NO. 6	NO. 8	NO. 10	NO. 12	NO. 14	NO. 4	NO. 6	NO. 8	NO. 10	NO. 12	NO. 14
3/8	-	-	-	-	-	-	-	T 25603	T 25611	-	-	-
1/2	T 25200	T 25204	T 25209	T 25215	-	-	T 25600	T 25604	T 25612	T 25619	T 25626	-
5/8	T 25201	T 25205	T 25210	T 25216	-	-	-	T 25605	T 25613	T 25620	-	-
3/4	T 25202	T 25206	T 25211	T 25217	R 25224	R 25230	T 25601	T 25606	T 25614	T 25621	T 25627	T 25632
1	-	T 25207	T 25212	T 25218	R 25225	R 25231	T 25602	T 25607	T 25615	T 25622	T 25628	T 25633
1-1/4	-	T 25208	R 25213	R 25219	R 25226	R 25232	-	T 25608	T 25616	T 25623	T 25629	T 25634
1-1/2	-	-	R 25214	R 25220	R 25227	R 25233	-	T 25609	T 25617	T 25624	T 25630	R 25635
2	-	-	T 25223	R 25221	R 25228	R 25234	-	T 25610	T 25618	T 25625	T 25631	R 25636

# STAINLESS STEEL DRILL AND TAP SCREWS

HEX WASHER HEAD						PHILLIPS PAN HEAD																	
<ul style="list-style-type: none"> <li>• REDUCES LABOR AND TOOLING COSTS</li> <li>• ELIMINATES NEED FOR DRILL BITS AND TAPS</li> <li>• MANUFACTURED OF 410 GRADE S/S FOR MAXIMUM STRENGTH*</li> </ul> <p>*NOTE: 410 stainless possesses magnetic properties</p>						 <p>17763</p> <p>APPLICATIONS: MAY BE USED IN MANY MATERIALS SUCH AS STRUCTURED STEEL, HARDWOOD AND MASONITE</p>						<ul style="list-style-type: none"> <li>• REDUCES LABOR AND TOOLING COSTS</li> <li>• ELIMINATES NEED FOR DRILL BITS AND TAPS</li> <li>• MANUFACTURED OF 410 GRADE S/S FOR MAXIMUM STRENGTH*</li> </ul> <p>*NOTE: 410 stainless possesses magnetic properties</p> <p>MAY BE USED IN MANY MATERIALS SUCH AS STRUCTURED STEEL, HARDWOOD AND MASONITE</p>											
LENGTH	NO. 6		NO. 8		NO. 10		NO. 12		NO. 14		NO. 6		NO. 8		NO. 10								
3/8	T	25350		—		—		—		—	T	25700		—		—							
1/2	T	25351	T	25354	T	25361		—		—	T	25701	T	25708	T	25714							
5/8		—	T	25355	T	25362		—		—		—		—		—							
3/4	T	25352	T	25356	T	25363	R	25368	R	25374	T	25703	T	25710	T	25716							
1	T	25353	T	25357	T	25364	R	25369	R	25375	T	25704	T	25711	T	25717							
1-1/4		—	R	25358	R	25365	R	25370	R	25376	T	25705	T	25712	T	25718							
1-1/2		—	R	25359	R	25366	R	25371	R	2537	T	25706	T	25713	T	25719							
2		—	R	25360	R	25367	R	25372	N	25378		—		—		—							
2-1/2		—		—		—	N	25373	N	25379		—		—		—							
3		—		—		—		—	N	25380		—		—		—							
4		—		—		—		—	I	25381		—		—		—							

# STAINLESS STEEL THREADED ROD

## USS THREADED ROD TYPE 18-8 (300 SERIES)

6 FOOT LENGTHS - 72"			
		RESISTS RUST, CORROSION, ACIDS AND CHEMICALS.	
SIZE	PART	SIZE	PART
4-40	A 15050	3/8-16	A 15065
6-32	A 15052	7/16-14	A 15068
8-32	A 15054	1/2-13	A 15070
10-24	A 15058	5/8-11	A 15075
10-32	A 15056	3/4-10	A 15080
1/4-20	A 15060	7/8-9	A 15085
5/16-18	A 15062	1-8	A 15090

3 FOOT LENGTHS - 36"			
		RESISTS RUST, CORROSION, ACIDS AND CHEMICALS.	
SIZE	PART	SIZE	PART
4-40	A 14040	3/8-16	A 14055
6-32	A 14042	7/16-14	A 14058
8-32	A 14044	1/2-13	A 14060
10-24	A 14048	5/8-11	A 14065
10-32	A 14046	3/4-10	A 14070
1/4-20	A 14050	7/8-9	A 14075
5/16-18	A 14052	1-8	A 14080

# STAINLESS STEEL KEY STOCK

S/S SQUARE KEY STOCK			
<ul style="list-style-type: none"> <li>• USE IN CORROSIVE, CAUSTIC AND SANITARY ENVIRONMENTS</li> <li>• MACHINE CUT ENDS</li> <li>• TOLERANCES: -.002 TO +.000 IN BOTH DIMENSIONS</li> <li>• MATERIAL 303 STAINLESS</li> </ul>			 <p>17799</p>
SIZE	PART	SIZE	PART
1/8	C 63460	1/2	A 63465
3/16	C 63461	5/8	A 63466
1/4	B 63462	3/4	A 63467
5/16	A 63463	7/8	A 63468
3/8	A 63464	1"	A 63469

STAINLESS STEEL WOODRUFF KEYS			
		<p>17796</p>	
WIDTH X DIA.	PART	WIDTH X DIA.	PART
1/16 x 1/2	E 63430	3/16 x 5/8	E 63437
3/32 x 1/2	E 63431	3/16 x 3/4	E 63438
1/8 x 1/2	E 63432	3/16 x 7/8	E 63439
1/8 x 5/8	E 63433	1/4 x 3/4	E 63440
1/8 x 3/4	E 63434	1/4 x 7/8	B 63441
5/32 x 5/8	E 63435	1/4 x 1	B 63442
5/32 x 3/4	E 63436	—	—

# S/S SPRING PINS AND COTTER PINS

## S/S SPRING PINS

• 420 STAINLESS STEEL FOR  
MAXIMUM STRENGTH AND  
CORROSION RESISTANCE

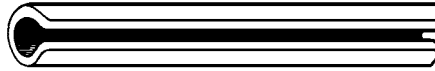

LENGTH	1/16 DIA.		5/64 DIA.		3/32 DIA.		1/8 DIA.		5/32 DIA.		3/16 DIA.	
		PART		PART		PART		PART		PART		PART
1/4	T	47200	T	47206	T	47212		-		-		-
3/8	T	47201	T	47207	T	47213	T	47222				
7/16		-		-	T	47214						
1/2	T	47202	T	47208	T	47215	T	47223	T	47230	T	47237
9/16		-		-	T	47216		-		-		-
5/8	T	47203	T	47209	T	47217	T	47224	T	47231	T	47238
3/4	T	47204	T	47210	T	47218	T	47225	T	47232	T	47239
7/8		-		-	T	47219	T	47226	T	47233	T	47240
1	T	47205	T	47211	T	47220	T	47227	T	47234	T	47241
1-1/4		-		-	T	47221	T	47228	T	47235	T	47242
1-1/2		-		-		-	T	47229	T	47236	R	47243
1-3/4		-		-		-		-		-	R	47244
2		-		-		-		-		-	R	47245

LENGTH	7/32 DIA.		1/4 DIA.		5/16 DIA.		3/8 DIA.		7/16 DIA.		1/2 DIA.	
		PART		PART		PART		PART		PART		PART
5/8	T	47246	R	47253		-		-		-		-
3/4	T	47247	R	47254	R	47264	N	47276		-		-
7/8		-		-	N	47265		-		-		-
1	R	47248	R	47255	R	47266	N	47277	I	47284		-
1-1/4	R	47249	R	47256	N	47267	N	47278	I	47285		-
1-3/8		-		-	N	47268		-		-		-
1-1/2	R	47250	R	47257	N	47269	I	47279	I	47286	E	47291
1-3/4	R	47251	R	47258	N	47270	I	47280	I	47287	E	47292
2	R	47252	R	47259	N	47271	I	47281	I	47288	E	47293
2-1/4		-	N	47260	I	47272		-		-		-
2-1/2		-	N	47261	I	47273	I	47282	E	47289	E	47294
2-3/4		-	N	47262	I	47274		-		-		-
3		-	N	47263	I	47275	I	47283	E	47290	E	47295
3-1/2		-		-		-		-		-	E	47296

## 18-8 S/S COTTER PINS

EASY TO INSERT,  
LOCK AND REMOVE



LENGTH	1/16	3/32	7/64	1/8	5/32	3/16	1/4
1/2	U 14538	U 14543	-	-	-	-	-
3/4	U 14539	-	-	-	-	-	-
1	U 14540	U 14545	T 14570	U 14549	T 14553	-	-
1-1/2	U 14541	U 14547	R 14571	T 14550	T 14555	R 14559	N 14564
2	-	T 14546	-	T 14552	R 14554	R 14560	R 14565
2-1/2	-	-	-	T 14551	R 14556	-	N 14566
3	-	-	-	-	N 14557	R 14561	-

# STAINLESS STEEL THUMB SCREWS

- PRECISION BURR-FREE THREADS FOR EXACT FIT
- MINIMUM TENSILE STRENGTH – 100,000 PSI
- YIELD – 55,000 PSI
- HARDNESS – 100 ROCKWELL B MINIMUM



LENGTH	8-32		10-24		10-32		1/4-20		5/16-18		3/8-16	
<b>1/2</b>	L	44500	L	44504	L	44507	L	44510	I	44516		-
<b>3/4</b>	I	44501	I	44505	I	44508	I	44511	I	44517	I	44520
<b>1</b>	I	44502	I	44506	I	44509	I	44512	E	44518	C	44521
<b>1-1/4</b>		-		-		-	I	44513		-		-
<b>1-1/2</b>	E	44503		-		-	I	44514		-	C	44522
<b>2</b>		-		-		-	I	44515	E	44519	C	44523

# BRASS MACHINE SCREWS

## SLOTTED ROUND HEAD

- NON-MAGNETIC PROPERTIES AND GOOD CORROSION RESISTANCE
- TENSILE STRENGTH 55,000 TO 65,000 PSI MIN.

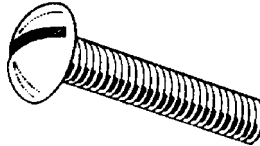

LENGTH	4-40		6-32		8-32		10-24		10-32		12-24		1/4-20		5/16-18	
<b>1/4</b>	R	37701	R	37712	R	37724	R	37738	R	37757		-		-		-
<b>3/8</b>	R	37702	R	37714	R	37726	R	37740	R	37759		-	R	37783		-
<b>1/2</b>	R	37704	R	37715	R	37727	R	37741	R	37760	R	37773	R	37784	N	37802
<b>5/8</b>	R	37705	R	37716	R	37728	R	37742	R	37761		-		-		-
<b>3/4</b>	R	37706	R	37717	R	37729	R	37743	R	37762	R	37775	N	37786		-
<b>7/8</b>		-		-		-		-		-		-	R	37787		-
<b>1</b>	R	37707	R	37719	R	37731	R	37745	R	37764		-	N	37788		-
<b>1-1/4</b>	R	37708	R	37720	R	37732	R	37746	R	37765		-	N	37789		-
<b>1-1/2</b>	R	37709	R	37721	R	37733	R	37747	R	37766		-	N	37790	N	37806
<b>2</b>		-	R	37722	R	37735	N	37749	N	37768		-	N	37792		-
<b>2-1/2</b>		-		-		-	N	37751	N	37769		-	N	37794		-
<b>3</b>		-		-		-		-	N	37770		-	N	37796		-

## FLAT HEAD

- NON-MAGNETIC PROPERTIES AND GOOD CORROSION RESISTANCE
- TENSILE STRENGTH 55,000 TO 65,000 PSI MIN.

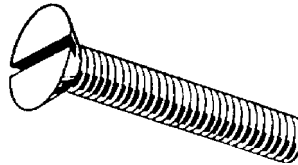

LENGTH	4-40		6-32		8-32		10-24		10-32		1/4-20	
<b>1/4</b>	T	47701	T	47712	T	47724	T	47738	T	47757		-
<b>3/8</b>	T	47702	T	47714	T	47726	T	47740	T	47759		-
<b>1/2</b>	T	47704	T	47715	T	47727	T	47741	T	47760	R	47784
<b>5/8</b>	T	47705	T	47716	T	47728	T	47742	T	47761		-
<b>3/4</b>	T	47706	T	47717	T	47729	T	47743	T	47762	R	47786
<b>1</b>	T	47707	T	47719	T	47731	T	47745	T	47764	R	47788
<b>1-1/4</b>	R	47708	R	47720	R	47732	R	47746	R	47765	R	47789
<b>1-1/2</b>	R	47709	R	47721	R	47733	R	47747	R	47766	R	47790
<b>2</b>		-		-	R	47735	R	47749	R	47768	N	47792
<b>2-1/2</b>		-		-		-	R	47751	R	47769	N	47794
<b>3</b>		-		-		-	R	47754	R	47770	N	47796

# BRASS NUTS AND WASHERS

## FOR BRASS MACHINE SCREWS

### HEX NUTS

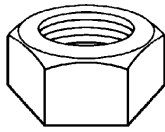

SIZE	PART	SIZE	PART
4-40	T 21100	5/16-18	T 21108
6-32	T 21102	3/8-16	R 21109
8-32	T 21103	1/2-13	N 21111
10-24	T 21104	5/8-11	L 21112
10-32 SAE	T 21105	3/4-10	I 21113
1/4-20	T 21107	1-8	B 21114

### USS FLATWASHERS

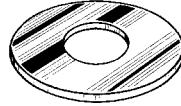

SIZE	PART
3/16	T 46715
1/4	T 46717
5/16	T 46719
3/8	T 46721
1/2	R 46725
5/8	N 46727
3/4	N 46729

### SAE FLATWASHERS

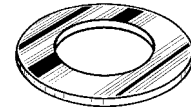

SIZE	PART	SIZE	PART
#6	U 46700	3/8	T 46706
#8	U 46701	1/2	R 46710
#10	T 46702	5/8	N 46711
1/4	T 46704	3/4	N 46712
5/16	T 46705	-	-

# BRASS WOOD SCREWS

## PHILLIPS

Solid brass alloy wood screws provides the ultimate in factory fit and finish in all wood applications.

### FLAT HEAD

- SOLID BRASS CONSTRUCTION ELIMINATES CORROSION AND GIVES FACTORY FINISH AND APPEARANCE IN ALL WOODS.
- EXTRA SHARP LEADER POINT FOR FASTER, EASIER STARTING.

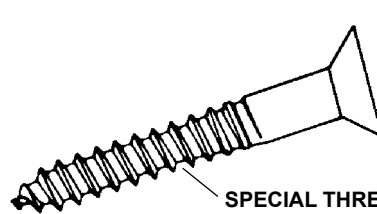

PRECISION PHILLIPS DRIVE ASSURES SOLID GRIP WITH SCREWDRIVER.

SPECIAL THREAD DESIGN ALLOWS FASTER, SMOOTHER DRIVING WITHOUT SPLINTERING OR SEPARATION OF WOOD BOARDS.



LENGTH	NO. 6		NO. 8		NO. 10		NO. 12	
1/2		—	T	7272		—		—
3/4		—	T	7274	T	7783	T	7289
1	R	7269	T	7276	T	7284	T	7290
1-1/2	T	7271	R	7278	R	7286	R	7292
2		—	N	7280	N	7288	N	7294

# S/S METRIC SOCKET HEAD CAP SCREWS

## STANDARD THREAD

Superior corrosion resistance to chemicals and sea water. High molybdenum content, high temperature strength and non-magnetic.

## HEX SOCKET HEAD

• 100,000 PSI TENSILE STRENGTH

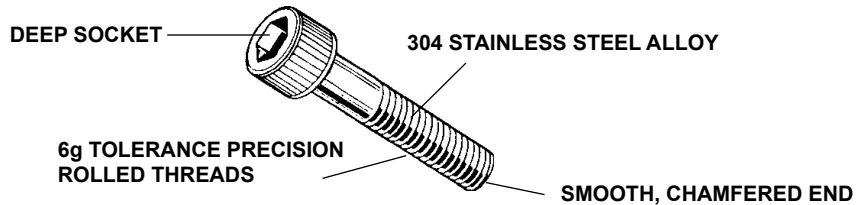

LENGTH	HEX SOCKET HEAD							
	2.5mm DIA. 0.45 Thr. Pch. 2mm Hex Key	3mm DIA. 0.50 Thr. Pch. 2.5mm Hex Key	4mm DIA. 0.70 Thr. Pch. 3mm Hex Key	5mm DIA. 0.80 Thr. Pch. 4mm Hex Key	6mm DIA. 1.00 Thr. Pch. 5mm HEX KEY			
6	T	15659	T	15665	T	15678	-	-
8	T	15660	T	15666	T	15679	T	15690
10	T	15661	T	15667	T	15680	T	15691
12	T	15662	T	15668	T	15681	T	15692
16	T	15663	T	15669	T	15682	T	15693
20	T	15664	T	15670	T	15683	T	15694
25		-	T	15671	T	15684	T	15695
30		-	T	15672	T	15685	T	15696
35		-	T	-	T	15686	T	15697
40		-	T	-	T	15687	R	15698
45		-		-		-	R	15699
50		-		-		-	R	15700
55		-		-		-		-
60		-		-		-	N	15716
		-		-		-	N	15717
LENGTH	HEX SOCKET HEAD							
	8mm DIA. 1.25 Thr. Pch. 6mm Hex Key	10mm DIA. 1.50 Thr. Pch. 8mm Hex Key	12mm DIA. 1.75 Thr. Pch. 10mm Hex Key	16mm DIA. 2.00 Thr. Pch. 14mm Hex Key				
10	N	15727	-	-	-			
12	R	15728	-	-	-			
16	R	15729	-	-	-			
20	R	15730	N	15749	L	15768		
25	R	15731	N	15750	L	15769		
30	R	15732	N	15751	L	15770		
35	R	15733	N	15752	L	15771		
40	R	15734	L	15753	L	15772		
45	R	15735	L	15754	L	15773		
50	N	15736	L	15755	L	15774		
55	N	15737	L	15756	I	15775		
60	N	15738	I	15757	I	15776		
70	L	15739	I	15758	I	15777		
80	I	15740	I	15759	I	15778		
90		-	E	15760	E	15779		
100		-	E	15761	E	15780		
110		-		-	E	15781		
120		-		-	E	15782		



# S/S METRIC FLAT SOCKET HEAD CAP SCREWS

## STANDARD THREAD

304 stainless steel. Deep socket assures full wrench engagement.

- 304 STAINLESS STEEL
- MEETS DIN 7991-A2
- TENSILE STRENGTH  
70,000 TO 100,000 PSI

DEEP SOCKET

EXCELLENT  
ELONGATION  
PROPERTIES

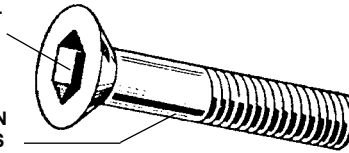

SMOOTH,  
CHAMFERED END



LENGTH	2.5mm DIA. 0.50 Thr. Pch.	3mm DIA. 0.50 Thr. Pch.	4mm DIA. 0.70 Thr. Pch.	5mm DIA. 0.80 Thr. Pch.	6mm DIA. 1.00 Thr. Pch.	8mm DIA. 1.25 Thr. Pch.	10mm DIA. 1.50 Thr. Pch.
4	R 69700	—	—	—	—	—	—
6	T 69701	T 69704	—	—	—	—	—
8	T 69702	T 69705	T 69710	—	—	—	—
10	T 69703	T 69706	T 69711	T 69716	T 69722	—	—
12	—	T 69707	T 69712	T 69717	T 69723	—	—
16	—	T 69708	T 69713	T 69718	T 69724	R 69731	—
20	—	—	T 69714	T 69719	T 69725	R 69732	I 69735
25	—	—	—	T 69720	T 69726	R 69733	I 69736
30	—	—	—	—	T 69727	R 69734	I 69737
35	—	—	—	—	—	—	I 69738
40	—	—	—	—	—	—	I 69739

# S/S METRIC BUTTON SOCKET HEAD CAP SCREWS

## STANDARD THREAD

304 stainless steel. Deep socket assures full wrench engagement.

- 304 STAINLESS STEEL
- MEETS DIN 7380-A2
- TENSILE STRENGTH  
70,000 TO 100,000 PSI

DEEP SOCKET

EXCELLENT  
ELONGATION  
PROPERTIES

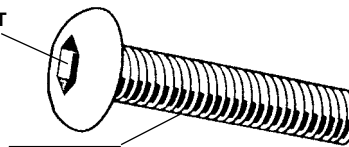

SMOOTH,  
CHAMFERED END



LENGTH	2.5mm DIA. 0.50 Thr. Pch.	3mm DIA. 0.50 Thr. Pch.	4mm DIA. 0.70 Thr. Pch.	5mm DIA. 0.80 Thr. Pch.	6mm DIA. 1.00 Thr. Pch.	8mm DIA. 1.25 Thr. Pch.	10mm DIA. 1.50 Thr. Pch.
4	T 69750	—	—	—	—	—	—
6	T 69751	T 69754	T 69759	—	—	—	—
8	T 69752	T 69755	T 69760	R 69765	R 69771	—	—
10	T 69753	T 69756	T 69761	T 69766	T 69772	—	—
12	—	T 69757	R 69762	T 69767	T 69773	—	—
16	—	T 69758	R 69763	T 69768	T 69774	N 69781	—
20	—	—	R 69764	T 69769	R 69775	N 69782	I 69785
25	—	—	—	T 69770	R 69776	N 69783	I 69786
30	—	—	—	—	N 69777	N 69784	I 69787
35	—	—	—	—	—	—	I 69788
40	—	—	—	—	—	—	I 69789

# S/S METRIC SOCKET SET SCREWS

- 304 STAINLESS STEEL
- MEETS DIN 916-A2
- TENSILE STRENGTH 70,000 TO 100,000 PSI



LENGTH	2.5mm DIA. 0.25 Thr. Pch. 1.5mm Hex Key	3mm DIA. 0.50 Thr. Pch. 1.5mm Hex Key	4mm DIA. 0.70 Thr. Pch. 2mm Hex Key	5mm DIA. 0.80 Thr. Pch. 2.5mm Hex Key	6mm DIA. 1.00 Thr. Pch. 3mm Hex Key	8mm DIA. 1.25 Thr. Pch. 4mm Hex Key	10mm DIA. 1.50 Thr. Pch. 5mm Hex Key	12mm DIA. 1.75 Thr. Pch. 6mm Hex Key
4	N 69790	T 69793	T 69796	-	-	-	-	-
5	-	-	-	T 69800	-	-	-	-
6	N 69791	T 69794	T 69797	T 69801	-	-	-	-
8	-	T 69795	T 69798	T 69802	T 69804	-	-	-
10	-	-	T 69799	T 69803	T 69805	R 69809	N 69814	-
12	-	-	-	-	R 69806	R 69810	N 69815	I 69820
16	-	-	-	-	R 69807	R 69811	N 69816	I 69821
20	-	-	-	-	R 69808	N 69812	I 69817	I 69822
25	-	-	-	-	-	N 69813	I 69818	I 69823
30	-	-	-	-	-	-	I 69819	I 69824

# METRIC STAINLESS STEEL CAP SCREWS

- STANDARD THREAD
- SUPERIOR CORROSION RESISTANCE TO CHEMICALS AND SEA WATER
- HIGH MOLYBDENUM CONTENT, HIGH TEMPERATURE RESISTANCE AND NON-MAGNETIC
- 100,000 PSI TENSILE STRENGTH
- DIN 933/931
- A2 (304) STAINLESS

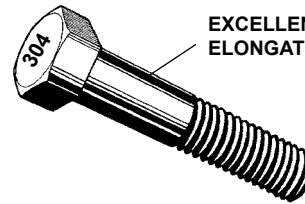

EXCELLENT  
ELONGATION PROPERTIES

SMOOTH,  
CHAMFERED END

LENGTH	3mm DIA. 0.50 THRD. PCH.	4mm DIA. 0.70 THRD. PCH.	5mm DIA. 0.80 THRD. PCH.	6mm DIA. 1.00 THRD. PCH.	8mm DIA. 1.25 THRD. PCH.
6	T 15900	-	-	-	-
8	T 15901	T 15904	-	-	-
10	-	T 15948	T 15909	T 15953	-
12	-	T 15905	T 15950	T 15914	R 15955
16	I 15902	T 15906	T 15910	T 15915	R 15920
20	I 15903	T 15907	T 15911	T 15916	R 15921
25	-	T 15949	T 15951	T 15954	R 15956
30	-	T 15908	T 15912	T 15917	R 15922
35	-	-	R 15952	-	R 15957
40	-	-	R 15913	R 15918	N 15923
45	-	-	-	-	N 15958
50	-	-	-	R 15919	N 15924
60	-	-	-	-	N 15925

LENGTH	10mm DIA. 1.50 THREAD PITCH	12mm DIA. 1.75 THREAD PITCH	16mm DIA. 2.00 THREAD PITCH	20mm DIA. 2.50 THREAD PITCH
20	N 15926	I 15932	-	-
25	N 15927	I 15933	E 15938	-
30	N 15928	I 15934	E 15939	-
35	N 15959	-	-	B 15943
40	L 15929	I 15935	E 15940	B 15962
45	-	-	-	B 15944
50	L 15930	I 15936	E 15941	B 15945
60	I 15931	I 15937	B 15942	B 15946
70	I 15960	I 15961	-	B 15947

# METRIC S/S PHILLIPS MACHINE SCREWS

## USE WITH STAINLESS STEEL METRIC NUTS AND WASHERS

Superior corrosion resistance to chemicals and sea water. High molybdenum content, high temperature strength and non-magnetic.

### PAN HEAD

- DIN 7985
- A2 (304) STAINLESS
- EXCELLENT RESISTANCE TO RUST AND CORROSION FROM ACIDS, ORGANIC SUBSTANCES, SALT SOLUTIONS AND ATMOSPHERE

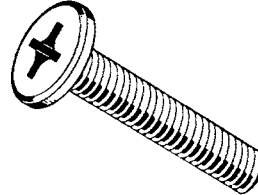

LENGTH		3mm DIA. 0.50 PITCH		4mm DIA. 0.70 PITCH		5mm DIA. 0.80 PITCH		6mm DIA. 1.0 PITCH
4	T	67998		-		-		-
5	T	67999		68008		-		-
6	T	68000	T	68009		-		-
8	T	68001	T	68010	R	68019	R	68028
10	T	68002	T	68011	R	68020	R	68029
12	T	68003	T	68012	R	68021	R	68030
16	T	68004	T	68013	R	68022	R	68031
20	T	68005	T	68014	R	68023	R	68032
25	T	68006	R	68015	R	68024	R	68033
30	R	68007	R	68016	R	68025	N	68034
35		-	R	68017	N	68026	N	68035
40		-	R	68018	N	68027	N	68036

# METRIC S/S THREADED ROD

## RESISTS RUST, CORROSION, ACIDS AND CHEMICALS



- DIN 975
- A2 (304) STAINLESS
- ONE METER LENGTHS

SIZE		PART	SIZE		PART	SIZE		PART	SIZE		PART
3mm	A	68660	5mm	A	68662	8mm	A	68664	12mm	A	68666
4mm	A	68661	6mm	A	68663	10mm	A	68665	-	A	-

# METRIC S/S NUTS AND WASHERS

## USE WITH STAINLESS STEEL METRIC CAP SCREWS

Superior corrosion resistance to chemicals and sea water. High molybdenum content, high temperature strength and non-magnetic.

### METRIC STAINLESS STEEL FLAT WASHERS

- DIN 125
- A2 (304) STAINLESS

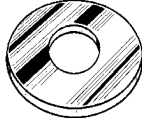

SIZE	I.D.	O.D.	THICKNESS	PART
2mm	2.2mm	5mm	0.3mm	T 15824
2.5mm	2.7mm	6mm	0.5mm	T 15825
3mm	3.2mm	7mm	0.5mm	T 15826
4mm	4.3mm	9mm	0.8mm	T 15827
5mm	5.3mm	10mm	1mm	T 15828
6mm	6.4mm	12mm	1.6mm	T 15829
8mm	8.4mm	16mm	1.6mm	T 15830
10mm	10.5mm	20mm	2mm	T 15831
12mm	13mm	24mm	2.5mm	R 15832
14mm	15mm	28mm	2.5mm	N 15833
16mm	17mm	30mm	3mm	N 15834
20mm	21mm	37mm	3mm	N 15836

### METRIC STAINLESS STEEL LOCK WASHERS

- DIN 127
- A2 (304) STAINLESS

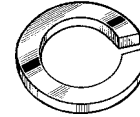

SIZE	I.D.	O.D.	THICKNESS	PART
2mm	2.1mm	4.4mm	0.5mm	T 15837
2.5mm	2.6mm	5.1mm	0.6mm	T 15838
3mm	3.1mm	6.2mm	0.8mm	T 15839
4mm	4.1mm	7.6mm	0.9mm	T 15840
5mm	5.1mm	9.2mm	1.2mm	T 15841
6mm	6.1mm	11.8mm	1.6mm	T 15842
8mm	8.1mm	14.8mm	2mm	T 15843
10mm	10.2mm	18.1mm	2.2mm	T 15844
12mm	12.2mm	21.1mm	2.5mm	R 15845
14mm	14.2mm	24.1mm	3mm	R 15846
16mm	16.2mm	27.4mm	3.5mm	R 15847
20mm	20.2mm	33.6mm	4mm	N 15849

### METRIC STAINLESS STEEL HEX NUTS

- DIN 934
- A2 (304) STAINLESS

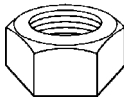

SIZE	WAF	HEIGHT	PART
2mm x 0.40	4mm	1.6mm	T 15798
2.5mm x 0.45	5mm	2mm	T 15799
3mm x 0.50	5.5mm	2.4mm	T 15800
4mm x 0.70	7mm	3.2mm	T 15801
5mm x 0.80	8mm	4mm	T 15802
6mm x 1.00	10mm	5mm	T 15803
8mm x 1.25	13mm	6.5mm	T 15804
10mm x 1.50	17mm	8mm	R 15805
12mm x 1.75	19mm	10mm	N 15806
14mm x 2.00	22mm	11mm	I 15807
16mm x 2.00	24mm	13mm	I 15808
20mm x 2.50	30mm	16mm	I 15810

### METRIC S/S NYLON INSERT LOCK NUTS

- DIN 985
- FOR TEMPERATURES  
-100 TO 250°F
- A2 (304) STAINLESS

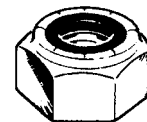

SIZE	WAF	HEIGHT	PART
3mm x 0.50	5.5mm	4mm	T 15813
4mm x 0.70	7mm	5mm	T 15814
5mm x 0.80	8mm	5mm	T 15815
6mm x 1.00	10mm	6mm	T 15816
8mm x 1.25	13mm	8mm	T 15817
10mm x 1.50	17mm	10mm	R 15818
12mm x 1.75	19mm	12mm	N 15819
14mm x 2.00	22mm	14mm	I 15820
16mm x 2.00	24mm	16mm	I 15821
20mm x 2.50	30mm	20mm	E 15823



# BIN ASSORTMENTS

## USS 18-8 STAINLESS STEEL FASTENERS

### *40-Compartment Steel Bin*



***You Receive a 40-Compartment Bin Labeled for 40 of the Fastest Moving Sizes Needed in Maintenance!***

**PART NO. 7817**

**ONE STEEL 40-HOLE BIN**

33-3/4" wide, 22-1/2" high, 12" deep\*

\*Can be shipped via UPS

**INCLUDED IN THE ORIGINAL ASSORTMENT YOU WILL RECEIVE 40 DIFFERENT ITEMS. YOU WILL BE ABLE TO FILL IN ADDITIONAL SIZES EACH MONTH ON MY SERVICE CALL. COMPARTMENTS ARE FULLY LABELED.**  
(See Plan-A-Graph for complete details)

#### **ASSORTMENT CONTAINS:**

25 Sizes Stainless Steel Cap Screws ..... 1/4" thru 1/2" Diameter  
5 Sizes Stainless Steel Hex Nuts ..... 1/4" thru 1/2" Diameter  
5 Sizes Stainless Steel Flat Washers ..... 1/4" thru 1/2" Diameter  
5 Sizes Stainless Steel Lock Washers ..... 1/4" thru 1/2" Diameter

1 P/N 7903 — 40 Compartment Bin

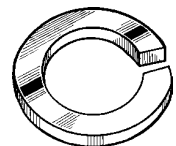
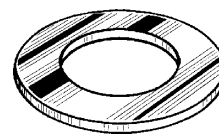
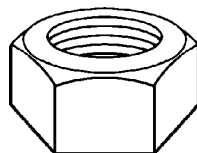
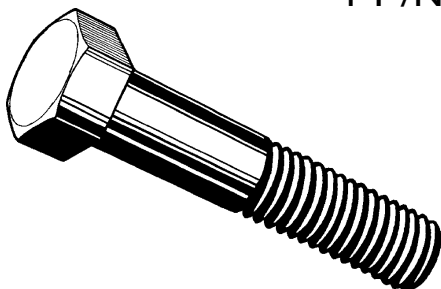

# USS 18-8 STAINLESS STEEL FASTENER ASSORTMENT

**P/N 7817 — USS SIZES — 40 ITEMS / 40 HOLES**

1/4-20 HEX NUT 14300	1/4 FLAT WASHER 14510	1/4 LOCK WASHER 14410	1/4-20 x 1/2 CAP SCREW 14100	1/4-20 x 3/4 CAP SCREW 14106	1/4-20 x 1 CAP SCREW 14109	1/4-20 x 1-1/2 CAP SCREW 14115	1/4-20 x 2 CAP SCREW 14121
5/16-18 HEX NUT 14302	5/16 FLAT WASHER 14512	5/16 LOCK WASHER 14412	5/16-18 x 1/2 CAP SCREW 14143	5/16-18 x 3/4 CAP SCREW 14149	5/16-18 x 1 CAP SCREW 14152	5/16-18 x 1-1/2 CAP SCREW 14158	5/16-18 x 2 CAP SCREW 14164
3/8-16 HEX NUT 14304	3/8 FLAT WASHER 14514	3/8 LOCK WASHER 14414	3/8-16 x 3/4 CAP SCREW 14186	3/8-16 x 1 CAP SCREW 14189	3/8-16 x 1-1/4 CAP SCREW 14192	3/8-16 x 1-1/2 CAP SCREW 14195	3/8-16 x 2 CAP SCREW 14201
7/16-14 HEX NUT 14306	7/16 FLAT WASHER 14516	7/16 LOCK WASHER 14416	7/16-14 x 1 CAP SCREW 14220	7/16-14 x 1-1/4 CAP SCREW 14223	7/16-14 x 1-1/2 CAP SCREW 14226	7/16-14 x 2 CAP SCREW 14230	7/16-14 x 2-1/2 CAP SCREW 14233
1/2-13 HEX NUT 14308	1/2 FLAT WASHER 14518	1/2 LOCK WASHER 14418	1/2-13 x 1 CAP SCREW 14246	1/2-13 x 1-1/2 CAP SCREW 14252	1/2-13 x 2 CAP SCREW 14258	1/2-13 x 2-1/2 CAP SCREW 14261	1/2-13 x 3 CAP SCREW 14264

# BIN ASSORTMENTS

## USS 316 STAINLESS STEEL FASTENERS

### *40-Compartment Steel Bin*



***You Receive a 40-Compartment Bin Labeled for 40 of the Fastest Moving Sizes Needed in Maintenance!***

### **PART NO. 7869**

**ONE STEEL 40-HOLE BIN**

33-3/4" wide, 22-1/2" high, 12" deep\*

\*Can be shipped via UPS

**INCLUDED IN THE ORIGINAL ASSORTMENT YOU WILL RECEIVE 32 DIFFERENT ITEMS. YOU WILL BE ABLE TO FILL IN ADDITIONAL SIZES EACH MONTH ON MY SERVICE CALL. COMPARTMENTS ARE FULLY LABELED.**  
(See Plan-A-Graph for complete details)

#### **ASSORTMENT CONTAINS:**

20 Sizes Stainless Steel Cap Screws ..... 1/4" thru 1/2" Diameter  
4 Sizes Stainless Steel Hex Nuts ..... 1/4" thru 1/2" Diameter  
4 Sizes Stainless Steel Flat Washers ..... 1/4" thru 1/2" Diameter  
4 Sizes Stainless Steel Lock Washers ..... 1/4" thru 1/2" Diameter

1 P/N 7903 — 40 Compartment Bin

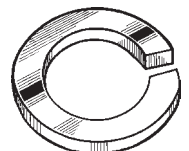
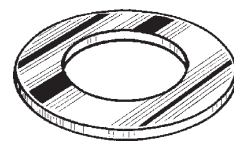
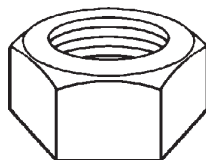
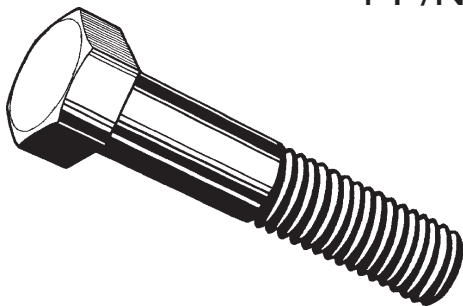



# USS 316 STAINLESS STEEL FASTENER ASSORTMENT

**P/N 7869 — USS SIZES — 32 ITEMS / 40 HOLES**

1/4-20 HEX NUT 13300	1/4 FLAT WASHER 13510	1/4 LOCK WASHER 13410	1/4-20 x 1/2 CAP SCREW 13100	1/4-20 x 3/4 CAP SCREW 13106	1/4-20 x 1 CAP SCREW 13109	1/4-20 x 1-1/2 CAP SCREW 13115	1/4-20 x 2 CAP SCREW 13121
5/16-18 HEX NUT 13302	5/16 FLAT WASHER 13512	5/16 LOCK WASHER 13412	5/16-18 x 1/2 CAP SCREW 13143	5/16-18 x 3/4 CAP SCREW 13149	5/16-18 x 1 CAP SCREW 13152	5/16-18 x 1-1/2 CAP SCREW 13158	5/16-18 x 2 CAP SCREW 13164
3/8-16 HEX NUT 13304	3/8 FLAT WASHER 13514	3/8 LOCK WASHER 13414	3/8-16 x 3/4 CAP SCREW 13186	3/8-16 x 1 CAP SCREW 13189	3/8-16 x 1-1/4 CAP SCREW 13192	3/8-16 x 1-1/2 CAP SCREW 13195	3/8-16 x 2 CAP SCREW 13201
EXPANSION	EXPANSION	EXPANSION	EXPANSION	EXPANSION	EXPANSION	EXPANSION	EXPANSION
1/2-13 HEX NUT 13308	1/2 FLAT WASHER 13518	1/2 LOCK WASHER 13418	1/2-13 x 1 CAP SCREW 13246	1/2-13 x 1-1/2 CAP SCREW 13252	1/2-13 x 2 CAP SCREW 13258	1/2-13 x 2-1/2 CAP SCREW 13261	1/2-13 x 3 CAP SCREW 13264